



Main

Range of product	Telemecanique Inductive proximity sensors XS
Series name	Application
Product or component type	Sensor
Sensor type	Inductive proximity sensor
Device application	Rotation monitoring
Sensor name	XS9
Sensor design	Flat form 26 x 26 x 13
Size	13 mm
Body type	Fixed
Detector flush mounting acceptance	Flush mountable
Material	Plastic
Enclosure material	PBT
Type of output signal	Discrete
Wiring technique	2-wire
[Sn] nominal sensing distance	10 mm
Discrete output function	1 NC
Output circuit type	AC/DC
Electrical connection	Remote male connector 1/2"20 UNF, 3 pins
Cable length	0.15 m
[Us] rated supply voltage	24...240 V AC/DC 50/60 Hz
Switching capacity in mA	5...100 mA AC/DC
IP degree of protection	IP67 double insulation conforming to IEC 60529

Complementary

Detection face	Frontal
Front material	PBT
Sensing range	> 8...15 mm
Adjustable frequency range	6...6000 cyc/mn
Operating zone	0...8 mm
Differential travel	3...15% of Fr
Repeat accuracy	3% of Sr
Wire insulation material	PvR
Status LED	Supply on: 1 LED (green) Output state: 1 LED (yellow)
Supply voltage limits	20...264 V AC/DC
Maximum residual current	1.5 mA open state
Switching frequency	<= 800 Hz
Maximum voltage drop	<5.5 V (closed)
Run-up delay at power-up	9 s standard
Marking	CE
Depth	13 mm
Height	26 mm
Width	26 mm
Net weight	0.04 kg

Environment

Product certifications	CSA UL CCC
Ambient air temperature for operation	-25...70 °C
Ambient air temperature for storage	-40...85 °C
Vibration resistance	25 gn amplitude = +/- 2 mm (f = 10...55 Hz) conforming to IEC 60068-2-6
Shock resistance	50 gn for 11 ms conforming to IEC 60068-2-27

Packing Units

Unit Type of Package 1	PCE
Number of Units in Package 1	1
Package 1 Weight	62 g
Package 1 Height	4.2 cm
Package 1 width	6.8 cm
Package 1 Length	9.5 cm
Unit Type of Package 2	S02
Number of Units in Package 2	44
Package 2 Weight	3.032 kg
Package 2 Height	15 cm
Package 2 width	30 cm
Package 2 Length	40 cm

Offer Sustainability

REACH Regulation	REACH Declaration
EU RoHS Directive	Pro-active compliance (Product out of EU RoHS legal scope) EU RoHS Declaration
Mercury free	Yes
RoHS exemption information	Yes

Contractual warranty

Warranty	18 months
----------	-----------

Dimensions

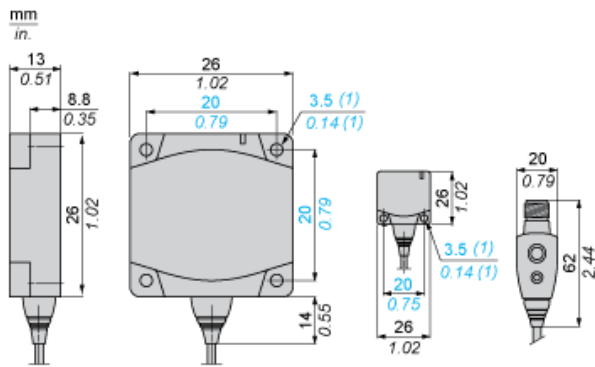

(1) For CHC type screws

Setting-up

Minimum Mounting Distances (mm)

Side by Side

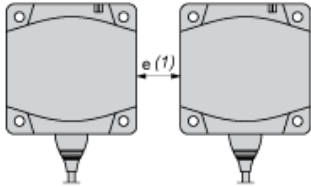

$e (1) \geq 40$

Face to Face

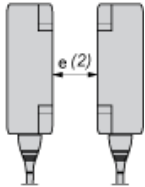

$e (2) \geq 80$

Wiring Schemes

2-Wire DC (Non Polarised)

