

# XMLP500MC71F

Electronic pressure sensors, Pressure sensors XM, transmitter 500mbar, 0...10 V, G1/4 A male, FPM, DIN



## Main

Range of product	OsiSense XM
Product or component type	Electronic pressure sensors
Pressure sensor type	Pressure transmitter
Pressure sensor name	XMLP
Electrical circuit type	Control circuit
Pressure rating	500 mbar
Local display	Without
Controlled fluid	Fresh water (0...125 °C) Air (-15...125 °C) Gas (-15...125 °C) Hydraulic oil (-15...125 °C)
Fluid connection type	G 1/4A (male) conforming to DIN 3852-E
Electrical connection	1 male connector EN 175301-803-A (ex DIN43650) 3 pins
[Us] rated supply voltage	24 V DC SELV (voltage limits: 12...33 V)
Current consumption	< 7 mA
Type of output signal	Analogue
Analogue output function	0...10 V, 3-wire
Quantity per set	Set of 1
Type of packing	Individual

## Complementary

Pressure setting range	0...0.5 bar
Maximum permissible accidental pressure	3 bar
Destruction pressure	5 bar
Materials in contact with fluid	Stainless steel AISI 316L Ceramic Fluorocarbon FPM
Operating position	Any position
Protection type	Load short-circuit Reverse polarity
Electromagnetic compatibility	Susceptibility to electromagnetic fields conforming to EN/IEC 61000-4-3 10 V/m 80...1000 MHz Electrical fast transient/burst immunity test conforming to EN/IEC 61000-4-4 2 kV Radiated RF fields conforming to EN/IEC 61000-4-6 10 V 0.15...80 MHz Electrostatic discharge immunity test conforming to EN/IEC 61000-4-2 8 kV air, 4 kV contact 1.2/50 µs shock waves immunity test conforming to EN/IEC 61000-4-5 1 kV 42 Ohm Immunity to magnetic fields conforming to EN/IEC 61000-4-8 100 A/m 50 Hz
[Uimp] rated impulse withstand voltage	0.5 kV
Response time on output	<= 2 ms 92 % of full scale
Measurement accuracy	+/- 1.5 % of the measuring range
Drift of the sensitivity	+/- 0.02 % of measuring range/°K
Drift of the zero point	+/- 0.03 % of measuring range/°K
Long term stability	+/- 0.1 % of the measuring range
Mechanical durability	10000000 cycles

The information provided in this documentation contains general descriptions and/or technical characteristics of the performance of the products contained herein. This documentation is not intended as a substitute for and is not to be used for determining suitability or reliability of these products for specific user applications. It is the duty of any such user or integrator to perform the appropriate and complete risk analysis, evaluation and testing of the products with respect to the relevant specific application or use thereof. Neither Schneider Electric Industries SAS nor any of its affiliates or subsidiaries shall be responsible or liable for misuse of the information contained herein.

Net weight	0.095 kg
Diameter	26 mm
Length	55 mm

## Environment

Standards	EN/IEC 61326-2-3 NSF ANSI 61
Product certifications	EAC RCM CE CULus
Ambient air temperature for operation	-30...85 °C
Ambient air temperature for storage	-50...100 °C
Vibration resistance	20 gn (f = 10...2000 Hz) conforming to EN/IEC 60068-2-6
Shock resistance	100 gn for 11 ms conforming to EN/IEC 60068-2-27
IP degree of protection	IP65 conforming to EN/IEC 60529

## Packing Units

Unit Type of Package 1	PCE
Number of Units in Package 1	1
Package 1 Weight	95 g
Package 1 Height	4.1 cm
Package 1 width	4.5 cm
Package 1 Length	8.5 cm

## Offer Sustainability

Sustainable offer status	Green Premium product
REACH Regulation	<a href="#">REACH Declaration</a>
REACH free of SVHC	Yes
EU RoHS Directive	Pro-active compliance (Product out of EU RoHS legal scope) <a href="#">EU RoHS Declaration</a>
Mercury free	Yes
RoHS exemption information	<a href="#">Yes</a>
Environmental Disclosure	<a href="#">Product Environmental Profile</a>

Dimensions

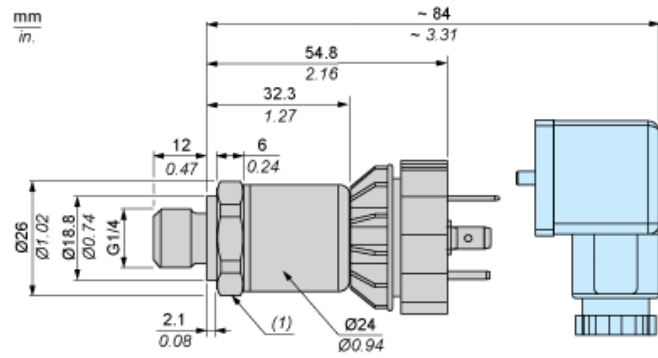

(1) SW24 tightening torque  $\leq 25$  N.m / 221 lb-in

---

## Connection and Schema

---

### Wiring Diagram

2-Wire Technique (4-20 mA)

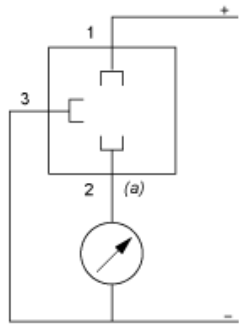

(a) V out

---

Performance Curves

---

Curves

