



Main

Range of product	Telemecanique Photoelectric sensors XU
Series name	General purpose multimode
Electronic sensor type	Photo-electric sensor transmitter
Sensor name	XUK
Sensor design	Compact 50 x 50
Detection system	Thru beam
Material	Plastic
Supply circuit type	AC/DC
Wiring technique	2-wire
Electrical connection	Cable
Cable length	2 m
Product specific application	-
Emission	Infrared thru beam
[Sn] nominal sensing distance	30 m thru beam need a receiver

Complementary

Enclosure material	PBT
Lens material	PMMA
Maximum sensing distance	35 m thru beam
Add on input	Test by emission breaking
Wire insulation material	PvR
Status LED	1 LED (green) for supply on
[Us] rated supply voltage	12...240 V DC 24...240 V AC
Supply voltage limits	10...264 V DC 20...264 V AC
Switching capacity in mA	3 A (cos ϕ = 1 for 0.5 million cycles at 1 operating cycle per second at 250 V)
Switching frequency	\leq 20 Hz
Maximum voltage drop	$<$ 1.5 V (closed state)
Time delay range	0...10 s monostable, on-delay or off-delay (programmable) delay
Setting-up	Without sensitivity adjustment
Depth	50 mm
Height	50 mm
Width	18 mm

Environment

Product certifications	CSA CE UL
Ambient air temperature for operation	-25...55 °C
Ambient air temperature for storage	-40...70 °C
Vibration resistance	7 gn, amplitude = +/- 1.5 mm (f = 10...55 Hz) conforming to IEC 60068-2-6
Shock resistance	30 gn (duration = 11 ms) conforming to IEC 60068-2-27
IP degree of protection	IP65 double insulation conforming to IEC 60529

Packing Units

Package 1 Weight	0.154 kg
Package 1 Height	1.320 dm
Package 1 width	0.950 dm
Package 1 Length	0.420 dm

Offer Sustainability

Sustainable offer status	Green Premium product
REACH Regulation	REACH Declaration
EU RoHS Directive	Pro-active compliance (Product out of EU RoHS legal scope) EU RoHS Declaration
Mercury free	Yes
RoHS exemption information	Yes
Environmental Disclosure	Product Environmental Profile
Circularity Profile	End Of Life Information

Contractual warranty

Warranty	18 months
----------	-----------

Dimensions

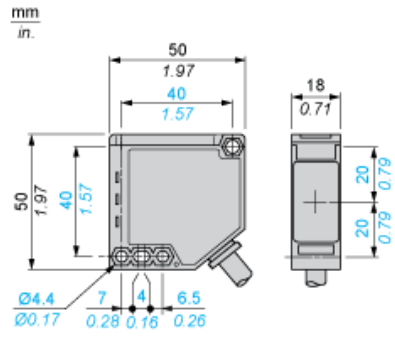

Wiring Schemes

Thru-beam Transmitter AC

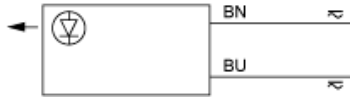

BN : Brown
BU : Blue

Detection Curves

With Thru-beam Accessory (Thru-beam)

