

### Main

Range of product	Telemecanique Safety light curtains XUSL
Accessory / separate part category	Spare parts
Accessory / separate part type	Anti-vibration kit
Product compatibility	XUSL4E XUSL2E
Accessory / separate part destination	Safety light curtain type 4 Safety light curtain type 2
Height protected	160 mm

### Complementary

Kit composition	4 damper(s)
Net weight	0.05 kg

### Packing Units

Package 1 Weight	0.013 kg
Package 1 Height	0.200 dm
Package 1 width	1.200 dm
Package 1 Length	1.800 dm

### Offer Sustainability

Sustainable offer status	Green Premium product
REACH Regulation	<a href="#">REACH Declaration</a>
REACH free of SVHC	Yes
EU RoHS Directive	Pro-active compliance (Product out of EU RoHS legal scope) <a href="#">EU RoHS Declaration</a>
Toxic heavy metal free	Yes
Mercury free	Yes
RoHS exemption information	<a href="#">Yes</a>
Environmental Disclosure	<a href="#">Product Environmental Profile</a>
Circularity Profile	<a href="#">End Of Life Information</a>

The information provided in this documentation contains general descriptions and/or technical characteristics of the performance of the products contained herein. This documentation is not intended as a substitute for and is not to be used for determining suitability or reliability of these products for specific user applications. It is the duty of any such user or integrator to perform the appropriate and complete risk analysis, evaluation and testing of the products with respect to the relevant specific application or use thereof. Neither Schneider Electric Industries SAS nor any of its affiliates or subsidiaries shall be responsible or liable for misuse of the information contained herein.

## Dimensions

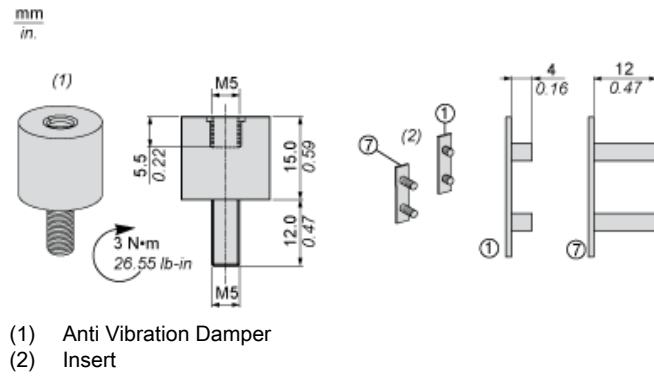

---

Mounting and Clearance

---

