



Main

Accessory / separate part designation	Clip-on 90° fixing bracket
Accessory / separate part destination	Flat form 40 x 40 x 15 sensor Flat form 40 x 40 x 15 tag Flat form 40 x 40 x 15 station
Accessory / separate part category	Mounting and fixing accessories
Accessory / separate part type	Fixing bracket
Product compatibility	XS flat form 40 x 40 x 15 XG flat form 40 x 40 x 15
Quantity per set	Set of 1
Additional information	Mounting possible without clip on tapped hole

Complementary

Net weight	0.06 kg
------------	---------

Packing Units

Package 1 Weight	0.076 kg
Package 1 Height	0.420 dm
Package 1 width	0.960 dm
Package 1 Length	0.670 dm

Offer Sustainability

Sustainable offer status	Green Premium product
REACH Regulation	REACH Declaration
EU RoHS Directive	Pro-active compliance (Product out of EU RoHS legal scope) EU RoHS Declaration
Mercury free	Yes
RoHS exemption information	Yes
Environmental Disclosure	Product Environmental Profile
Circularity Profile	End Of Life Information

Contractual warranty

Warranty	18 months
----------	-----------

The information provided in this documentation contains general descriptions and/or technical characteristics of the performance of the products contained herein. This documentation is not intended as a substitute for and is not to be used for determining suitability or reliability of these products for specific user applications. It is the duty of any such user or integrator to perform the appropriate and complete risk analysis, evaluation and testing of the products with respect to the relevant specific application or use thereof. Neither Schneider Electric Industries SAS nor any of its affiliates or subsidiaries shall be responsible or liable for misuse of the information contained herein.

Dimensions

Mounting Brackets

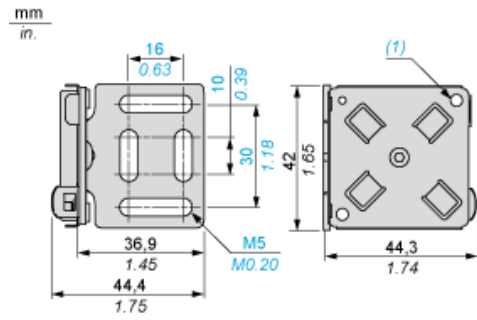

(1) 4 screws M4 x 14