

XY2CJL15H29

Latching emergency stop rope pull switch,
Telemecanique Emergency stop rope pull
switches XY2C, e XY2CJ, left side, 1NC+1 NO,
ISO M20

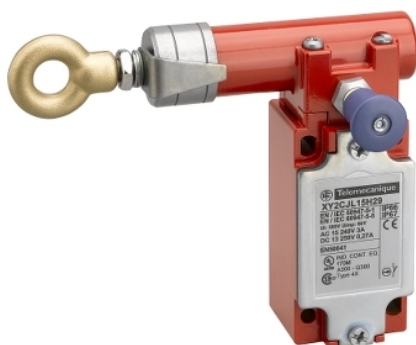

Main

Range of product	Telemecanique Emergency stop rope pull switches XY2C
Product or component type	Latching emergency stop rope pull switch
Device short name	XY2C
Housing colour	Red RAL 3000
Overvoltage category	Class I conforming to EN/IEC 61140

Complementary

Local signalling	Color indicator
Number of cables	1
Trigger cable maximum length	30 m
Body material	Zamak
Cover material	Galvanised steel
Reset	By pull button
Contacts type and composition	1 NC + 1 NO
Contact operation	Slow-break
Trigger cable anchor point	LH side
Connections - terminals	Screw clamp terminal, 1 x 0.5...2 x 1.5 mm ²
Tightening torque	0.8...1.2 N.m
Cable entry number	1 tapped entry for ISO M20 cable gland
Safety level	Can reach PL = e with the appropriate monitoring system and correctly wired conforming to EN/ISO 13849-1 Can reach category 4 with the appropriate monitoring system and correctly wired conforming to EN/ISO 13849-1 Can reach SIL 3 with the appropriate monitoring system and correctly wired conforming to EN/IEC 61508
Safety reliability data	B10d = 500000 conforming to IEC 60947-5-5 value given for a life time of 20 years limited by mechanical or contact wear
Marking	CE
Mechanical durability	100000 cycles
Distance between cable supports	5 m
[Ie] rated operational current	3 A at 240 V, AC-15, A300 conforming to EN/IEC 60947-5-1 appendix A 0.27 A at 250 V, DC-13, Q300 conforming to EN/IEC 60947-5-1 appendix A
[Ithe] conventional enclosed thermal current	10 A
[Ui] rated insulation voltage	500 V (pollution degree 3) conforming to EN/IEC 60947-1 300 V conforming to UL 508 300 V conforming to CSA C22.2 No 14
[Uimp] rated impulse withstand voltage	EN/IEC 60947-1 6 kV
Positive opening	With conforming to EN/IEC 60947-5-1
Maximum resistance across terminals	25 MOhm conforming to EN/IEC 60255-7 category 3 25 MOhm conforming to NF C 93-050 method A
Short-circuit protection	10 A cartridge fuse type gG conforming to EN/IEC 60269

Terminals description ISO n°1	(13-14)NO (21-22)NC
Net weight	0.669 kg
Compatibility code	XY2CJ



Environment

Standards	Machinery directive 2006/42/EC EN/ISO 13850 EN/IEC 60947-5-1 EN/IEC 60947-5-5 EN/IEC 60204-1 UL 508 Work equipment directive 2009/104/EC CSA C22.2 No 14
Product certifications	UL category NISD emergency stop devices CSA CCC EAC
Protective treatment	TC
Ambient air temperature for operation	-25...70 °C
Ambient air temperature for storage	-40...70 °C
Vibration resistance	10 gn (f= 10...150 Hz) conforming to EN/IEC 60068-2-6
Shock resistance	50 gn 11 ms conforming to EN/IEC 60068-2-27
IP degree of protection	IP66 conforming to IEC 60529 IP67 conforming to IEC 60529

Packing Units

Package 1 Weight	0.883 kg
Package 1 Height	0.900 dm
Package 1 width	1.600 dm
Package 1 Length	2.030 dm

Offer Sustainability

Sustainable offer status	Green Premium product
REACH Regulation	 REACH Declaration
EU RoHS Directive	Pro-active compliance (Product out of EU RoHS legal scope)  EU RoHS Declaration
Mercury free	Yes
RoHS exemption information	 Yes
Environmental Disclosure	 Product Environmental Profile

Dimensions

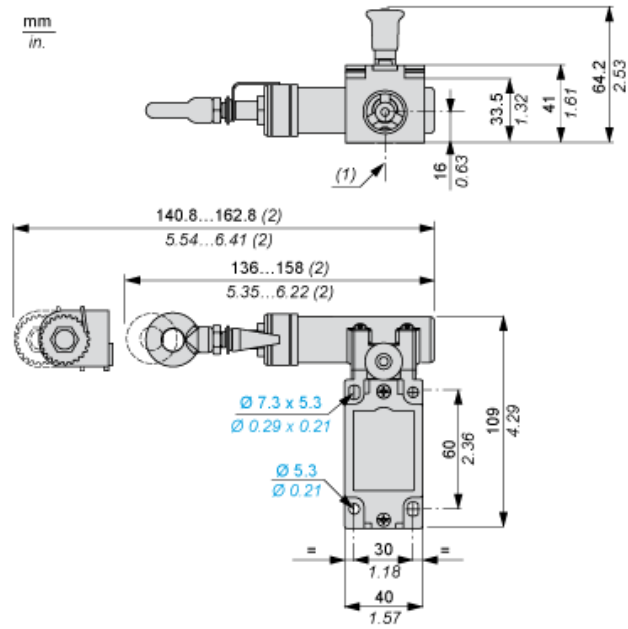

- (1) Tapped entry for ISO M20
(2) Maximum extension.

Electrical Curves

AC Supply 50/60 Hz Inductive Circuit

2-pole Contact Block

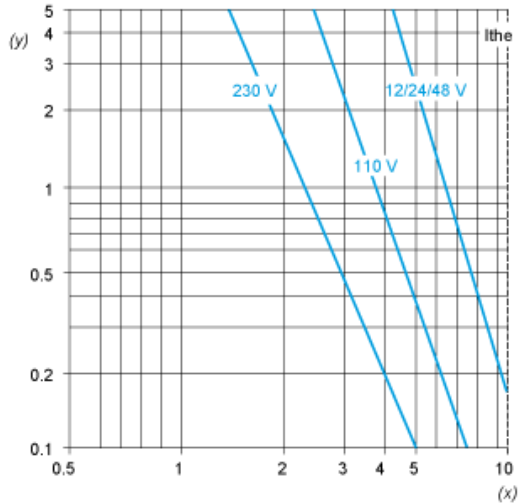

Y Millions of operating cycles
X Current in A

DC Supply Power Broken in for 1 Million Operating Cycles Inductive Circuit

Voltage	V	24	48	120
P_{max}	W	13	9	7