



Main

Range of product	Altivar 71Q
Product or component type	Variable speed drive
Device short name	ATV71Q
Product destination	Synchronous motors Asynchronous motors
Product specific application	Complex, high-power machines
Assembly style	With heat sink
Variant	Reinforced version
EMC filter	Integrated
Network number of phases	3 phases
[Us] rated supply voltage	380...480 V - 15...10 %
Supply voltage limits	323...528 V
Supply frequency	50...60 Hz - 5...5 %
Network frequency limits	47.5...63 Hz
Motor power kW	220 kW, 3 phases at 380...480 V 250 kW, 3 phases at 380...480 V
Motor power hp	350 Hp, 3 phases at 380...480 V 400 hp, 3 phases at 380...480 V
Maximum motor cable length	100 M shielded cable without motor choke 200 M unshielded cable without motor choke 250 M unshielded cable with motor choke 200 m shielded cable with motor choke
Line current	396 A for 380 V 3 phases 220 kW / 350 hp 444 A for 380 V 3 phases 250 kW / 400 hp 320 A for 480 V 3 phases 220 kW / 350 hp 357 A for 480 V 3 phases 250 kW / 400 hp

Complementary

Apparent power	260.6 kVA at 380 V 3 phases 220 kW / 350 hp 292.2 kVA at 380 V 3 phases 250 kW / 400 hp
Prospective line Isc	50 kA for 3 phases
Continuous output current	427 A at 2.5 kHz, 380 V - 3 phases 481 A at 2.5 kHz, 380 V - 3 phases 427 A at 2.5 kHz, 460 V - 3 phases 481 A at 2.5 kHz, 460 V - 3 phases
Maximum transient current	640 A for 60 s, 3 phases 721 A for 60 s, 3 phases 704 A for 2 s, 3 phases 793 A for 2 s, 3 phases
Speed drive output frequency	0.1...500 Hz
Nominal switching frequency	2.5 kHz
Switching frequency	2...8 kHz adjustable 2.5...8 kHz with derating factor
Speed range	1...100 for asynchronous motor in open-loop mode, without speed feedback 1...50 for synchronous motor in open-loop mode, without speed feedback 1...1000 for asynchronous motor in closed-loop mode with encoder feedback
Speed accuracy	+/- 0.01 % of nominal speed in closed-loop mode with encoder feedback 0.2 Tn to Tn +/- 10 % of nominal slip without speed feedback 0.2 Tn to Tn

The information provided in this documentation contains general descriptions and/or technical characteristics of the performance of the products contained herein. This documentation is not intended as a substitute for and is not to be used for determining suitability or reliability of these products for specific user applications. It is the duty of any such user or integrator to perform the appropriate and complete risk analysis, evaluation and testing of the products with respect to the relevant specific application or use thereof. Neither Schneider Electric Industries SAS nor any of its affiliates or subsidiaries shall be responsible or liable for misuse of the information contained herein.

Torque accuracy	+/- 5 % in closed-loop mode with encoder feedback +/- 15 % in open-loop mode, without speed feedback
Transient overtorque	170 % of nominal motor torque +/- 10 % for 60 s 220 % of nominal motor torque +/- 10 % for 2 s
Braking torque	30 % without braking resistor <= 150 % with braking or hoist resistor
Asynchronous motor control profile	Voltage/Frequency ratio, 2 points Flux vector control without sensor, 2 points Flux vector control without sensor, ENA (energy Adaptation) system Voltage/Frequency ratio - Energy Saving, quadratic U/f Voltage/Frequency ratio, 5 points Flux vector control with sensor, standard Flux vector control without sensor, standard
Synchronous motor control profile	Vector control with sensor, standard Vector control without sensor, standard
Regulation loop	Adjustable PI regulator
Motor slip compensation	Not available in voltage/frequency ratio (2 or 5 points) Suppressable Automatic whatever the load Adjustable
Local signalling	1 LED (red) for drive voltage
Output voltage	<= power supply voltage
Isolation	Electrical between power and control
Type of cable	Without mounting kit: 1 wire(s)IEC cable at 45 °C, copper 90 °C / XLPE/EPR Without mounting kit: 1 wire(s)IEC cable at 45 °C, copper 70 °C / PVC With an IP21 or an IP31 kit: 3 wire(s)IEC cable at 40 °C, copper 70 °C / PVC With a NEMA Type1 kit: 3 wire(s)UL 508 cable at 40 °C, copper 75 °C / PVC
Electrical connection	Terminal 2.5 mm ² / AWG 14 (AI1-/AI1+, AI2, AO1, R1A, R1B, R1C, R2A, R2B, LI1...LI6, PWR) Terminal 4 x 185 mm ² (L1/R, L2/S, L3/T, U/T1, V/T2, W/T3) Terminal 4 x 185 mm ² (PC/-, PA/+)
Tightening torque	41 N.M, 360 lb.in (L1/R, L2/S, L3/T, U/T1, V/T2, W/T3) 41 N.M, 360 lb.in (PC/-, PA/+) 0.6 N.m (AI1-/AI1+, AI2, AO1, R1A, R1B, R1C, R2A, R2B, LI1...LI6, PWR)
Supply	Internal supply for reference potentiometer (1 to 10 kOhm): 10.5 V DC, +/- 5 %, <10 mA with overload and short-circuit protection Internal supply: 24 V DC (21...27 V), <200 mA with overload and short-circuit protection
Analogue input number	2
Analogue input type	AI2 software-configurable voltage: 0...10 V DC 24 V max, impedance: 30000 Ohm, resolution 11 bits AI1-/AI1+ bipolar differential voltage: +/- 10 V DC 24 V max, resolution 11 bits + sign AI2 software-configurable current: 0...20 mA, impedance: 242 Ohm, resolution 11 bits
Sampling duration	2 Ms +/- 0.5 ms (LI6)if configured as logic input - discrete input 2 Ms +/- 0.5 ms (LI1...LI5) - discrete input 2 Ms +/- 0.5 ms (AI1-/AI1+) - analog output 2 ms +/- 0.5 ms (AI2) - analog output
Accuracy	+/- 0.6 % (AI1-/AI1+) for a temperature variation 60 °C +/- 0.6 % (AI2) for a temperature variation 60 °C +/- 1 % (AO1) for a temperature variation 60 °C
Linearity error	+/- 0.15 % of maximum value (AI1-/AI1+, AI2) +/- 0.2 % (AO1)
Analogue output number	1
Analogue output type	AO1 software-configurable voltage: 0...10 V DC, impedance: 470 Ohm, resolution 10 bits AO1 software-configurable current: 0...20 mA, impedance: 500 Ohm, resolution 10 bits AO1 software-configurable logic output 10 V 20 mA
Discrete output number	2
Discrete output type	Configurable relay logic: (R1A, R1B, R1C) NO/NC - 100000 cycles Configurable relay logic: (R2A, R2B) NO - 100000 cycles
Response time	R1A, R1B, R1C 7 ms, tolerance +/- 0.5 ms R2A, R2B 7 ms, tolerance +/- 0.5 ms AO1 2 ms, tolerance +/- 0.5 ms <= 100 ms in STO (Safe Torque Off)
Minimum switching current	3 mA at 24 V DC for configurable relay logic

Maximum switching current	5 A at 250 V AC on resistive load - $\cos \phi = 1$ - L/R = 0 ms (R1, R2) 5 A at 30 V DC on resistive load - $\cos \phi = 1$ - L/R = 0 ms (R1, R2) 2 A at 250 V AC on inductive load - $\cos \phi = 0.4$ - L/R = 7 ms (R1, R2) 2 A at 30 V DC on inductive load - $\cos \phi = 0.4$ - L/R = 7 ms (R1, R2)
Discrete input number	7
Discrete input type	LI1...LI5: programmable 24 V DC with level 1 PLC, impedance: 3500 Ohm LI6: switch-configurable 24 V DC with level 1 PLC, impedance: 3500 Ohm LI6: switch-configurable PTC probe 0...6, impedance: 1500 Ohm PWR: safety input 24 V DC, impedance: 1500 Ohm conforming to ISO 13849-1 level d
Discrete input logic	Positive logic (source) (LI6)if configured as logic input, < 5 V (state 0), > 11 V (state 1) Negative logic (sink) (LI6)if configured as logic input, > 16 V (state 0), < 10 V (state 1) Positive logic (source) (LI1...LI5), < 5 V (state 0), > 11 V (state 1) Negative logic (sink) (LI1...LI5), > 16 V (state 0), < 10 V (state 1) Positive logic (source) (PWR), < 2 V (state 0), > 17 V (state 1)
Acceleration and deceleration ramps	Automatic adaptation of ramp if braking capacity exceeded, by using resistor S, U or customized Linear adjustable separately from 0.01 to 9000 s
Braking to standstill	By DC injection
Protection type	Overheating protection: drive Thermal protection: drive Short-circuit between motor phases: drive Input phase breaks: drive Overcurrent between output phases and earth: drive Overvoltages on the DC bus: drive Break on the control circuit: drive Against exceeding limit speed: drive Line supply undervoltage: drive Line supply overvoltage: drive Against input phase loss: drive Thermal protection: motor Motor phase break: motor Power removal: motor
Dielectric strength	3535 V DC between earth and power terminals 5092 V DC between control and power terminals
Insulation resistance	> 1 mOhm 500 V DC for 1 minute to earth
Frequency resolution	Display unit: 0.1 Hz Analog input: 0.024/50 Hz
Communication port protocol	CANopen Modbus
Connector type	1 RJ45 (on front face) for Modbus 1 RJ45 (on terminal) for Modbus 1 RJ45 for CANopen
Physical interface	2-wire RS 485 for Modbus
Transmission frame	RTU for Modbus
Transmission rate	9600 bps, 19200 bps for Modbus on front face 4800 bps, 9600 bps, 19200 bps, 38.4 Kbps for Modbus on terminal 20 kbps, 50 kbps, 125 kbps, 250 kbps, 500 kbps, 1 Mbps for CANopen
Data format	8 bits, 1 stop, even parity for Modbus on front face 8 bits, odd even or no configurable parity for Modbus on terminal
Type of polarization	No impedance for Modbus
Number of addresses	1...247 for Modbus 1...127 for CANopen
Method of access	Slave CANopen
Type of cooling	Water cooled
Cooling fluid type	Clean water Industrial water Water-glycol mixture
Operating temperature water	5...55 °C
Thermal losses	5000 W 100 % of line current for area of liquid cooling (power part) 1010 W 100 % of line current for area of air cooling (control part)
Flow velocity	24
Maximum pressure drop	1 bar
Volume of cooling water	0.4 l
Operating position	Vertical +/- 10 degree
Net weight	140 kg

Option card	Communication card for Modbus TCP Communication card for Fipio Communication card for Modbus/Uni-Telway Communication card for Modbus Plus Communication card for EtherNet/IP Communication card for DeviceNet Communication card for Profibus DP Communication card for Profibus DP V1 Communication card for Interbus-S Communication card for CC-Link Interface card for encoder I/O extension card Controller inside programmable card Overhead crane card
Width	585 mm
Height	950 mm
Depth	377 mm

Environment

Ambient air temperature for operation	-10...50 °C (without derating)
Ambient air temperature for storage	-25...70 °C
Operating altitude	<= 1000 m without derating 1000...3000 m with current derating 1 % per 100 m
Electromagnetic compatibility	Electrostatic discharge immunity test level 3 conforming to IEC 61000-4-2 Radiated radio-frequency electromagnetic field immunity test level 3 conforming to IEC 61000-4-3 Electrical fast transient/burst immunity test level 4 conforming to IEC 61000-4-4 1.2/50 µs - 8/20 µs surge immunity test level 3 conforming to IEC 61000-4-5 Conducted radio-frequency immunity test level 3 conforming to IEC 61000-4-6 Voltage dips and interruptions immunity test conforming to IEC 61000-4-11
Pollution degree	2 conforming to EN/IEC 61800-5-1 3 conforming to UL 840
IP degree of protection	IP00 conforming to EN/IEC 61800-5-1 IP00 conforming to EN/IEC 60529 IP41 on upper part conforming to EN/IEC 61800-5-1 IP41 on upper part conforming to EN/IEC 60529 IP30 on the front panel conforming to EN/IEC 61800-5-1 IP30 on the front panel conforming to EN/IEC 60529 IP30 on side parts conforming to EN/IEC 61800-5-1 IP30 on side parts conforming to EN/IEC 60529 IP54 on lower part conforming to EN/IEC 61800-5-1 IP54 on lower part conforming to EN/IEC 60529
Vibration resistance	1.5 mm peak to peak (f= 3...10 Hz) conforming to EN/IEC 60068-2-6 0.6 gn (f= 10...200 Hz) conforming to EN/IEC 60068-2-6
Shock resistance	4 gn for 11 ms conforming to EN/IEC 60068-2-27
Relative humidity	5...95 % without condensation conforming to IEC 60068-2-3 5...95 % without dripping water conforming to IEC 60068-2-3
Noise level	77 dB conforming to 86/188/EEC
Standards	EN 61800-3 environments 2 category C3 EN 61800-3 environments 1 category C3 EN 55011 class A group 2 IEC 61508 SIL2 ISO 13849-1 level d IEC 60721-3-3 class 3C2 EN/IEC 61800-3 UL Type 1 EN/IEC 61800-5-1
Product certifications	GOST C-Tick UL CSA NOM 117
Marking	CE

Packing Units

Package 1 Weight	160.000 kg
Package 1 Height	5.300 dm
Package 1 width	6.350 dm
Package 1 Length	12.900 dm

Offer Sustainability

REACH Regulation	REACH Declaration
EU RoHS Directive	Pro-active compliance (Product out of EU RoHS legal scope) EU RoHS Declaration
Mercury free	Yes
RoHS exemption information	Yes
China RoHS Regulation	China RoHS Declaration
WEEE	The product must be disposed on European Union markets following specific waste collection and never end up in rubbish bins

Contractual warranty

Warranty	18 months
----------	-----------

Dimensions

Without or with 1 option card

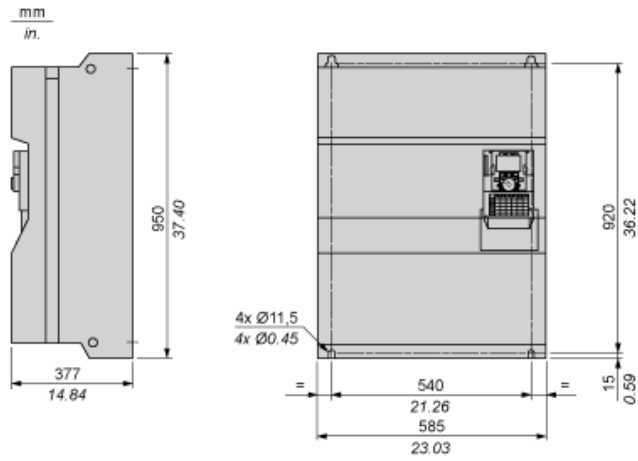

With 2 option cards

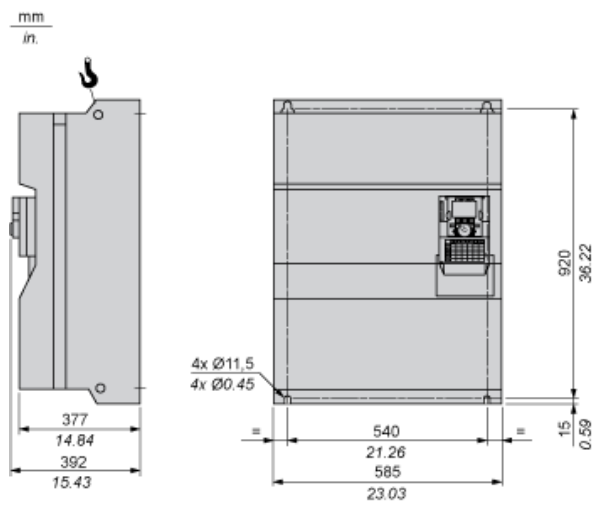

Clearance

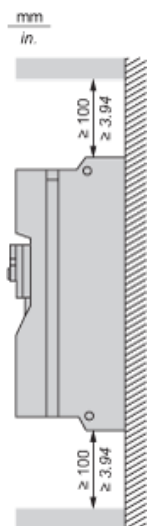

Wall-Mounting

The drive is designed for installation on the wall, in an electrical room or into an enclosure. The device is built according to pollution degree 2. If the environment does not correspond to these conditions then the necessary transition of the pollution degree must be provided e.g. by means of an enclosure.

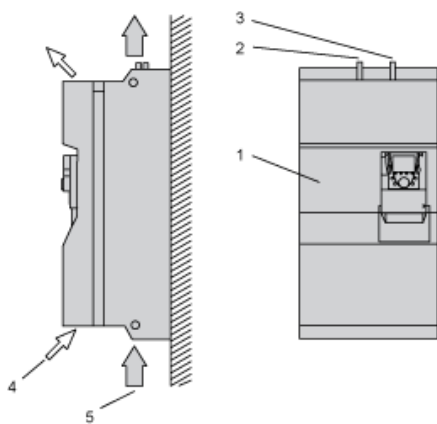

- (1) Drive
- (2) Cooling water inlet
- (3) Cooling water return
- (4) Cooling air for control part
- (5) Cooling air for power part (only capacitors)

Wiring Diagram

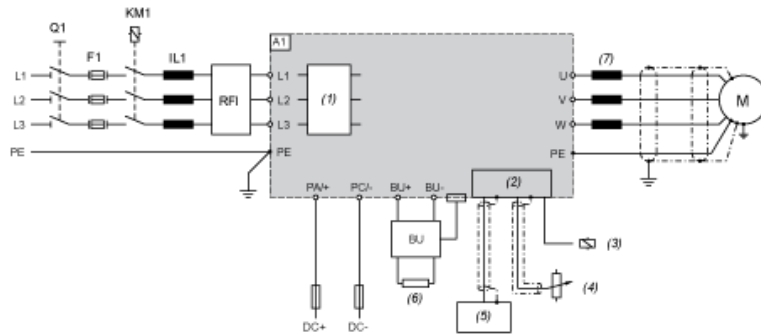

- A1 Drive
- BU Braking Unit
- F1 Fast-acting semi-conductor fuse
- IL1 Line choke
- KM1 Optional line contactor
- M Motor
- Q1 Switch
- RFI Optional radio frequency interference filter
- (1) Filter
- (2) Control
- (3) Relay control
- (4) Control potentiometer
- (5) PLC
- (6) External optional braking resistor
- (7) Optional motor choke

Continuous Current at Output Frequencies < 1 Hz

Due to the especially efficient liquid cooling of the drive the full overload capability is also available in the speed range of 0 Hz.

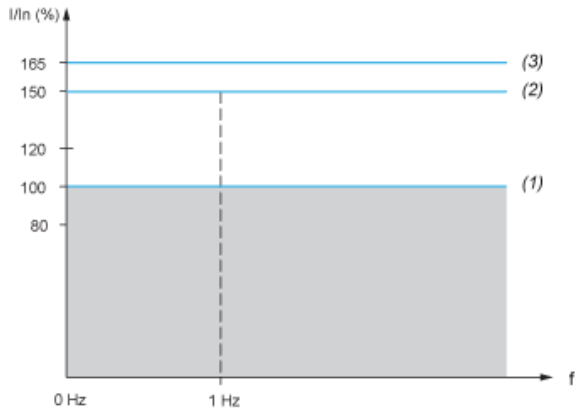

- (1) Continuous operation: 150% (165%) overload capability
- (2) Overload 150% for 60 s
- (3) Overload 165% for 2 s

Power Derating

4 kHz pulse frequency	+5°K air temperature
8%	10%